

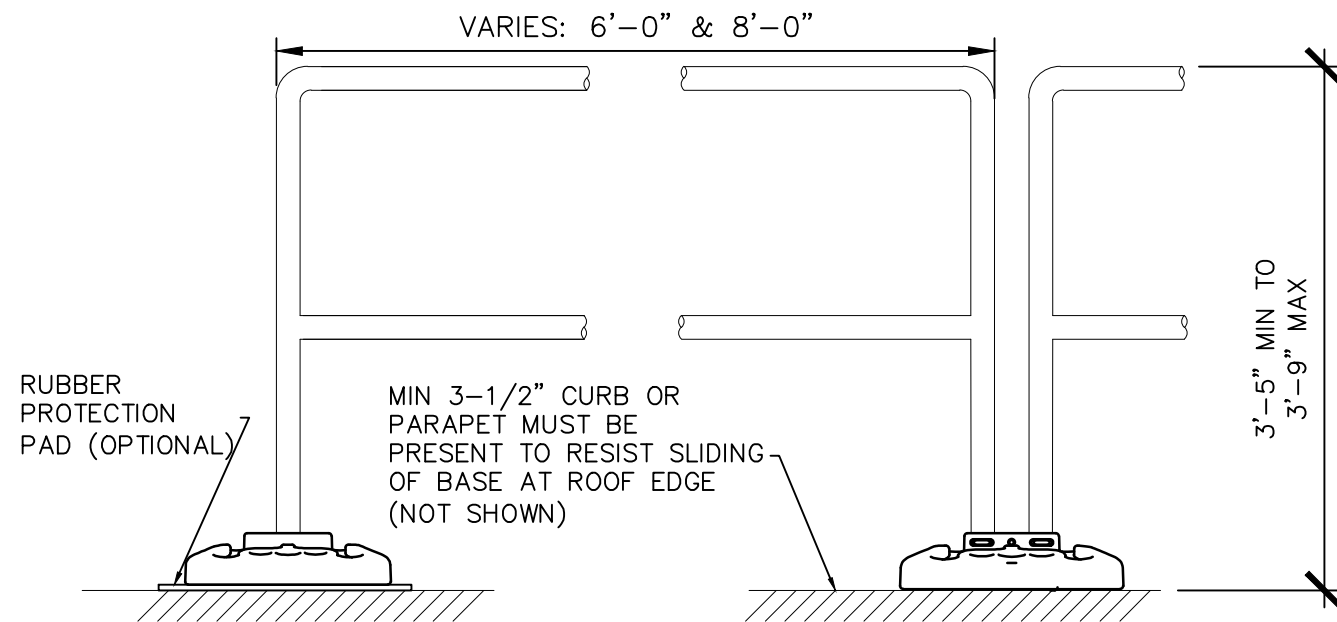

SAFETY PRODUCTS

TECHNICAL DATA SHEET
Cal-OSHA BALLASTED PORTABLE GUARDRAIL SYSTEM



REAR VIEW

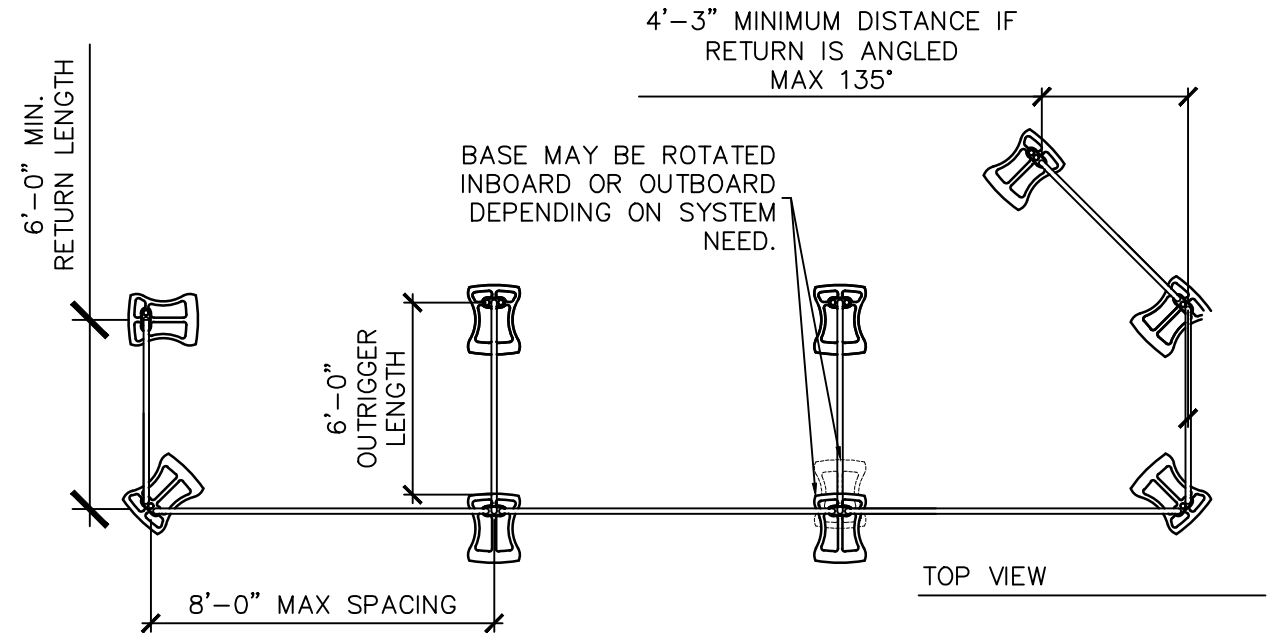
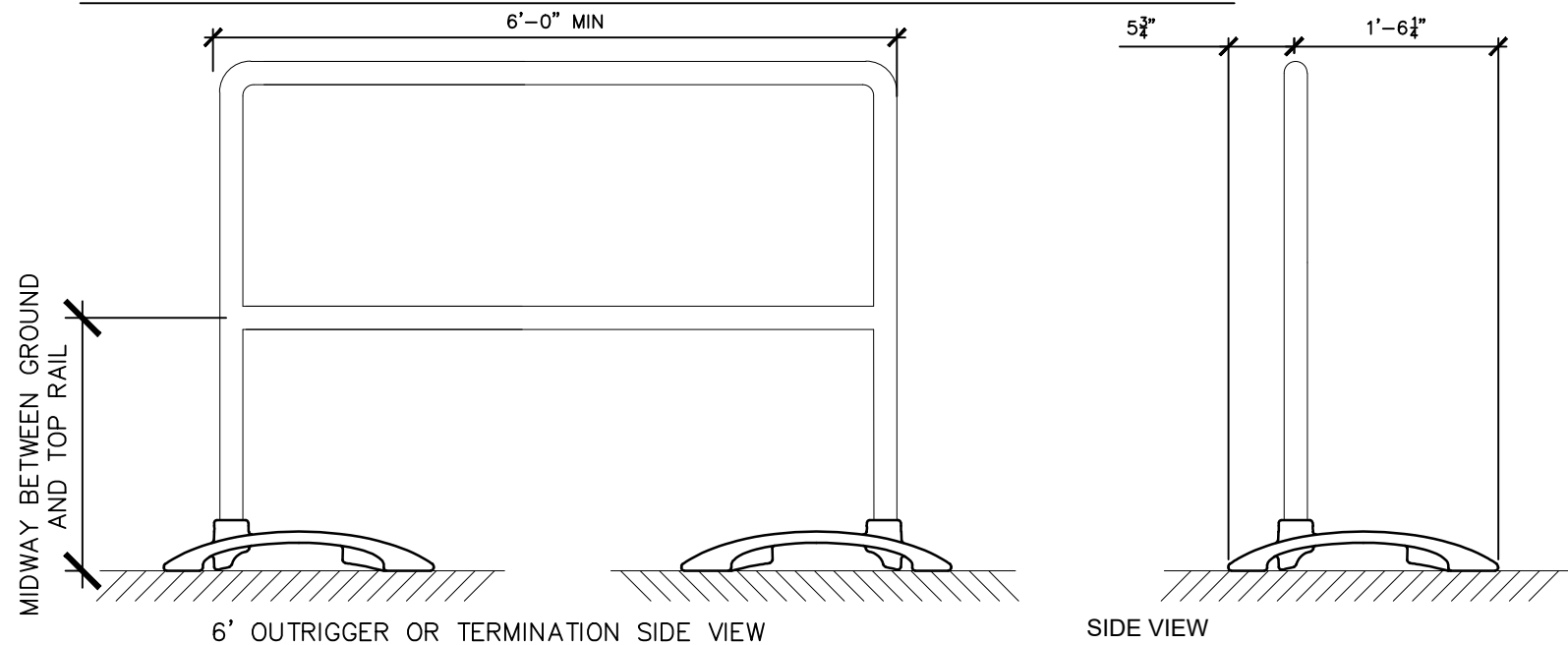

1. RETURNS ARE REQUIRED AT EACH SYSTEM END AND MUST BE 5' IN LENGTH MINIMUM. SPACING BETWEEN ANY POSTS MAY NOT EXCEED 8' WITH AN ADDITIONAL 6' OUTRIGGER AT SPACING AS PER SITE SPECIFIC DESIGN.
2. SYSTEM SHALL HAVE A TOP AND MID RAIL IN ACCORDANCE WITH OSHA STANDARDS – 29 CFR 1910.29 (B)(1), Cal-OSHA 3209(a).
3. RAILING MUST BE DESIGNED TO WITHSTAND A STRUCTURAL LOAD OF 200 LB (90.7 KG), MINIMUM, IN ANY DIRECTION TO ALL COMPONENTS WITHOUT FAILING IN ACCORDANCE WITH OSHA REGULATION 29 CFR 1926.502. THIS LOADING REPRESENTS AN INDIVIDUAL ACCIDENTALLY IMPACTING THE RAIL. DO NOT INTENTIONALLY LOAD THE GUARDRAIL.
4. RAILING ASSEMBLIES MUST BE DESIGNED TO RESIST A LOAD OF 20 PLF (0.73 kN/m) APPLIED IN ANY DIRECTION AT THE TOP AND TO TRANSFER THIS LOAD THROUGH THE SUPPORTS TO THE STRUCTURE. Cal-OSHA 3209(b)
5. TOP RAIL MUST BE 41"-45" VERTICAL FROM WALKING SURFACE. THE MIDRAIL SHOULD BE MID WAY BETWEEN THE TOP RAIL AND THE HIGHEST EXPOSED EDGE. TOE KICKS, IF INSTALLED, SHOULD BE 1/4" ABOVE THE WALKING SURFACE TO PREVENT PONDING. – Cal-OSHA 3209(a)
6. SYSTEM SHOULD BE USED ON A FLAT SURFACE NOT TO EXCEED 1/2:12 PITCH. SACRIFICIAL MEMBRANE MAY BE USED IF REQUIRED BY ROOF WARRANTY.'
7. REMOVE ALL LOOSE GRAVEL AND/OR MATERIALS IN THE VICINITY OF THE COUNTERWEIGHTED BASE. BASES MUST BE PLACED ON SOUND SUBSTRATE.
8. MIN 3" CURB OR PARAPET MUST BE PRESENT TO RESIST SLIDING OF BASE AT ROOF EDGE.
9. REFER TO SAFEPRO BALLASTED GUARDRAIL INSTALLATION MANUAL PRIOR TO INSTALLATION OF THESE PRODUCTS.
10. ALSO DESIGNED TO COMPLY WITH IBC 1607.8.1 REQUIREMENTS FOR AREAS THAT ARE NOT ACCESSIBLE TO GENERAL PUBLIC AND THAT HAVE AN OCCUPANT LOAD LESS THAN 50.

THE INFORMATION CONTAINED IN THIS DRAWING IS THE SOLE PROPERTY OF SAFEPRO SAFETY PRODUCTS. ANY REPRODUCTION IN PART OR AS A WHOLE WITHOUT WRITTEN PERMISSION OF SAFEPRO SAFETY PRODUCTS IS PROHIBITED.
 PROPRIETARY AND CONFIDENTIAL
 sales@safepro.com (877) 723-3570 www.safepro.com