

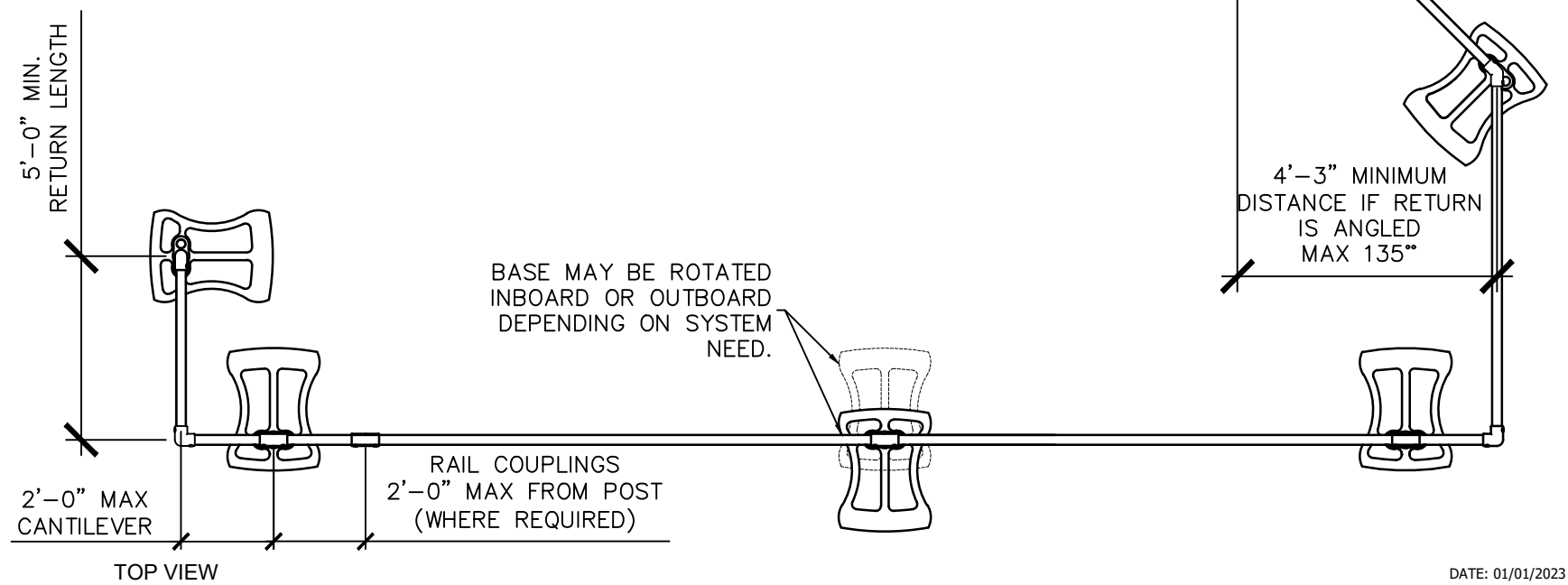

**SAFETY PRODUCTS**

TECHNICAL DATA SHEET  
**BALLASTED CONTOURED COMPONENT GUARDRAIL SYSTEM**

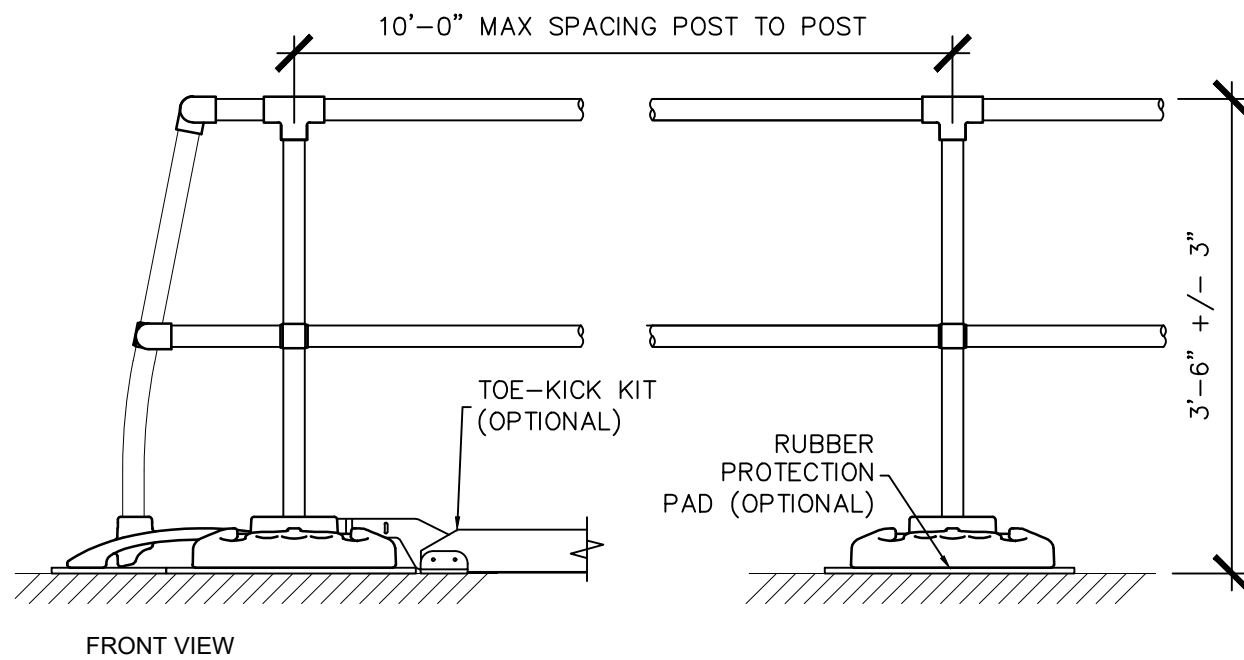

DATE: 01/01/2023

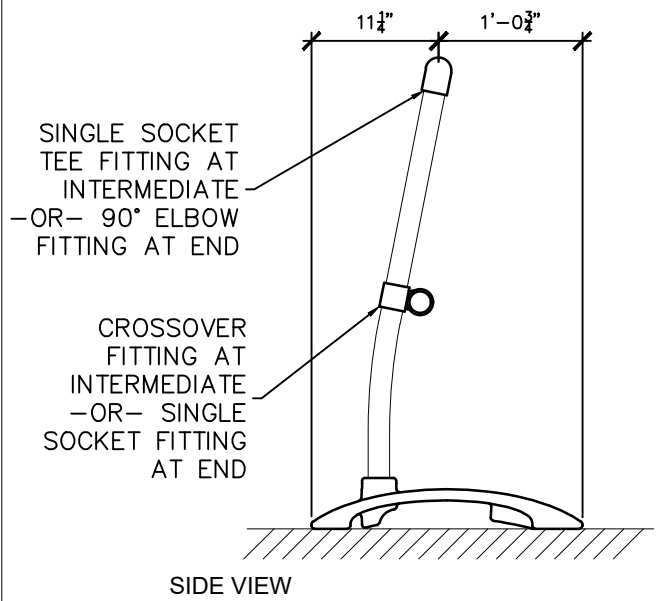

1. RETURNS ARE REQUIRED AT EACH SYSTEM END AND MUST BE A MINIMUM OF 5'. SPACING BETWEEN ANY POSTS MAY NOT EXCEED 10'.
2. SYSTEM SHALL HAVE A TOP AND MID RAIL IN ACCORDANCE WITH OSHA STANDARDS – 29 CFR 1910.29 (B)(1). THE GUARDRAIL IS CERTIFIED FOR USE IN FACTORIES, INDUSTRIAL, AND STORAGE OCCUPANCIES, IN AREAS THAT ARE NOT ACCESSIBLE TO THE PUBLIC AND THAT SERVE AN OCCUPANT LOAD NO GREATER THAN 50 AS PER ASCE 7-10 4.5.1 (2).
3. RAILING MUST BE DESIGNED TO WITHSTAND A LOAD OF 200 LB (90.7 KG), MINIMUM, IN ANY DIRECTION TO ALL COMPONENTS WITHOUT FAILING IN ACCORDANCE WITH OSHA REGULATION 29 CFR 1926.502 AND 29 CFR 1910.29. THIS LOADING REPRESENTS AN INDIVIDUAL ACCIDENTALLY IMPACTING THE RAIL. DO NOT INTENTIONALLY LOAD THE GUARDRAIL.
4. THE BALLASTED GUARDRAIL SYSTEM IS DESIGNED TO WITHSTAND AN ASCE 7-16 ULTIMATE WIND LOAD OF UP TO 130 MPH ON A RISK CATEGORY II BUILDING WITH EXPOSURE CATEGORY B. THE STANDARD DESIGN CONFIGURATION MAY BE RECONFIGURED BY SAFEPRO TO ACCOMMODATE ALTERNATE SITE CONDITIONS.
5. TOP RAIL MUST BE 42" (±3") VERTICAL FROM THE WALKING SURFACE. THE MIDRAIL SHOULD BE MID WAY BETWEEN THE TOP RAIL AND THE HIGHEST EXPOSED EDGE. TOE KICKS, IF INSTALLED, SHOULD BE 1/4" OFF THE WALKING SURFACE TO PREVENT PONDING.
6. SYSTEM SHOULD BE USED ON A FLAT SURFACE NOT TO EXCEED 1/2:12 PITCH.
7. INTEGRATED RUBBER PROTECTION PAD MAY BE USED ON ROOF MEMBRANE FOR ROOF PROTECTION. DO NOT INSTALL ON SLIPPERY SURFACES SUCH AS METAL OR TROWEL FINISHED CONCRETE.
8. REMOVE ALL LOOSE GRAVEL AND/OR MATERIALS IN THE VICINITY OF THE COUNTERWEIGHTED BASE. BASES MUST BE PLACED ON SOUND SUBSTRATE.
9. WHEN PARAPET DOES NOT EXIST, FRONT EDGE OF THE BASE SHALL BE SET BACK A MINIMUM OF 18" FROM THE LEADING EDGE.
10. REFER TO SAFEPRO BALLASTED GUARDRAIL INSTALLATION MANUAL PRIOR TO INSTALLATION OF THESE PRODUCTS.

	PIPE	BRACKETS/BASES
MATERIAL	ASTM A53	CAST IRON, GALV.
QUALITY	100% VISUAL INSPECTION	
COLOR	METALLIC	DULL METALLIC

PROPRIETARY AND CONFIDENTIAL  
 THE INFORMATION CONTAINED IN THIS DRAWING IS THE SOLE PROPERTY OF SAFEPRO SAFETY PRODUCTS. ANY REPRODUCTION IN PART OR AS A WHOLE WITHOUT WRITTEN PERMISSION OF SAFEPRO SAFETY PRODUCTS IS PROHIBITED.  
 sales@safeprosafety.com (877) 723-3570 www.safeprosafety.com

DATE: 01/01/2023